

Compact Wheel Loader

TAKEUCHI
From World First to World Leader

TW80 SERIES 3



Product Features & Specifications

ENGINE

- U.S. EPA Interim Tier 4 Emission
- DOC Exhaust After Treatment
- Turbocharged
- Water Cooled
- Dual Element Air Cleaner with Restriction Indicator
- High Capacity Radiator

ELECTRICAL

- Multi-Informational Monitor
- 12 volt System with 95 amp Alternator
- Work Lights: Front and Rear
- Driving Lights and Turn Signals
- Directional Lights: Fwd / Rev
- Engine Preheat
- Back-up Alarm

DRIVE TRAIN

- Hydrostatic Drive with 100% Inching Pedal
- 100% Locking Differentials: Front and Rear
- Two-Speed Travel
- Outboard Planetary Drives
- Spring Applied Parking Brake
- Multi-Wet Disc Brake
- Rigid Axles with Outboard Planetary Reduction
- 15 - 19.5 Heavy Duty Construction Tire Assembly (Optional)
- High Speed Road Gear with Ride Control (24.8 mph) (Optional)

OPERATOR'S STATION

- Enclosed Cab with Air Conditioning, Heat, Front and Rear Wipers, Front and Rear Washers, and Rear Defrost
- Elevated Operator's Station
- ROPS / FOPS Protection
- Deluxe Air Suspension Seat with Arm Rests
- Multi-Functional Joystick for Machine Direction Forward and Reverse and Loader Controls
- Auxiliary Circuit Thumb Switch and Loader Controls
- Large Steps and Grab Handles
- 2" Retractable Seat Belt
- 3" Retractable Seat Belt (Optional)

HYDRAULIC & WORKING EQUIPMENT

- Pilot Control
- Proportional Thumb Wheel for SSL Coupler or Auxiliary Hydraulic Circuit
- Auxiliary Hydraulic Lines Plumbed to End of Loader Arms
- Auxiliary Hydraulic Detent
- Hydraulic Oil Level Sight Gauge
- High Capacity Hydraulic Oil Cooler
- Z-Bar Linkage
- Bucket Float Function
- Mechanical Bucket Positioning
- Heavy Duty Hydraulic Bucket Quick Coupler
- Heavy Duty Self Aligning Loader Bushings with Oversized Pins
- 81.5" General Purpose Bucket (1.3 yds) (Optional)
- Bolt-On Reversible Cutting Edge for 81.5" Bucket (Optional)
- High Flow Auxiliary Hydraulics (26.0 gpm) (Optional)
- Combo Hitch to Universal SSL Adaptor (Optional)
- Flat Face Hydraulic Coupler Kit (Optional)



Operator's Station



Outboard Planetary Drives

TOUGH, POWERFUL, RELIABLE



The TW80 Series 3 features a compact design that is ideal for maneuvering in tight spaces with minimal damage to lawns and other sensitive surfaces. Delivering 73 horsepower, the TW80 Series 3 is equipped with a powerful, turbocharged Deutz engine that is EPA Final Tier 4 compliant. The loader has excellent reach, dump height, and lifting capabilities making it suitable for a wide variety of applications, and the

standard hydraulic coupler simplifies attachment exchanges. The operator's station is elevated and unobstructed for greater visibility and better job site awareness. Excellent power, precise control, lower operational and maintenance costs result in increased productivity and minimal downtime.



OPERATING PERFORMANCE

Operating Weight - Cab	12,700 lb	(5,760 kg)
Tipping Load, Straight	9,742 lb	(4,419 kg)
Tipping Load, Full Turn	8,602 lb	(3,902 kg)
Operating Capacity, SAE J818*	4,301 lb	(1,951 kg)
Bucket Breakout Force	13,960 lb	(6,333 kg)
Lift Arm Breakout Force	12,387 lb	(5,618 kg)
Traction Force	12,049 lb	(5,466 kg)
Travel Speed - Low Range	4.0 mph	(6.5 km/hr)
High Range	12.4 mph	(20.0 km/hr)
Optional High Speed Travel	24.8 mph	(40.0 km/hr)

* Rate Operating Capacity (ROC) for wheel loaders is rated with a bucket according to SAE J818 at no more than 50% of the full turn tipping load.

HYDRAULIC SYSTEM

Auxiliary Flow - Primary Circuit	16.4 gpm	(62.0 Lpm)
Auxiliary Flow - Optional Circuit	26.0 gpm	(98.0 Lpm)
Hydraulic System Pressure	3,335 psi	(23.0 MPa)

ENGINE

Make/Model	Deutz / TD2.9L Turbo	
Engine Displacement	176 cu in	(2.9 L)
Horsepower @ 2,200 rpm	73 hp	(54.0 kW)
Maximum Torque @ 1,800 rpm	192 ft-lb	(260.0 Nm)

FLUID CAPACITIES

Engine Lubrication	8.5 qt	(8.0 L)
Cooling System	13.7 qt	(13.0 L)
Fuel Tank Capacity	26.4 gal	(100.0 L)
Fuel Consumption (65% of Full Load)	2.6 gal/hr	(10.0 L/hr)
Hydraulic Reservoir Capacity	22.2 gal	(84.0 L)
Front Axle Lubrication	5.7 qt	(5.4 L)
Rear Axle Lubrication	5.4 qt	(5.1 L)



Deluxe Lighting Package



Z-Bar Linkage

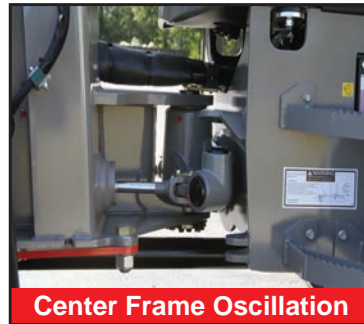

Center Frame Oscillation



Hydraulic Oil Sight Gauge

ATTACHMENTS

Takeuchi now offers attachments for all of your Takeuchi equipment. See your authorized Takeuchi dealer for addition information and attachment options.



4-in-1 Bucket



Low Profile Buckets



Grapple -Brush



Grapple - Scrap

TW80 Series 3 Wheel Loader

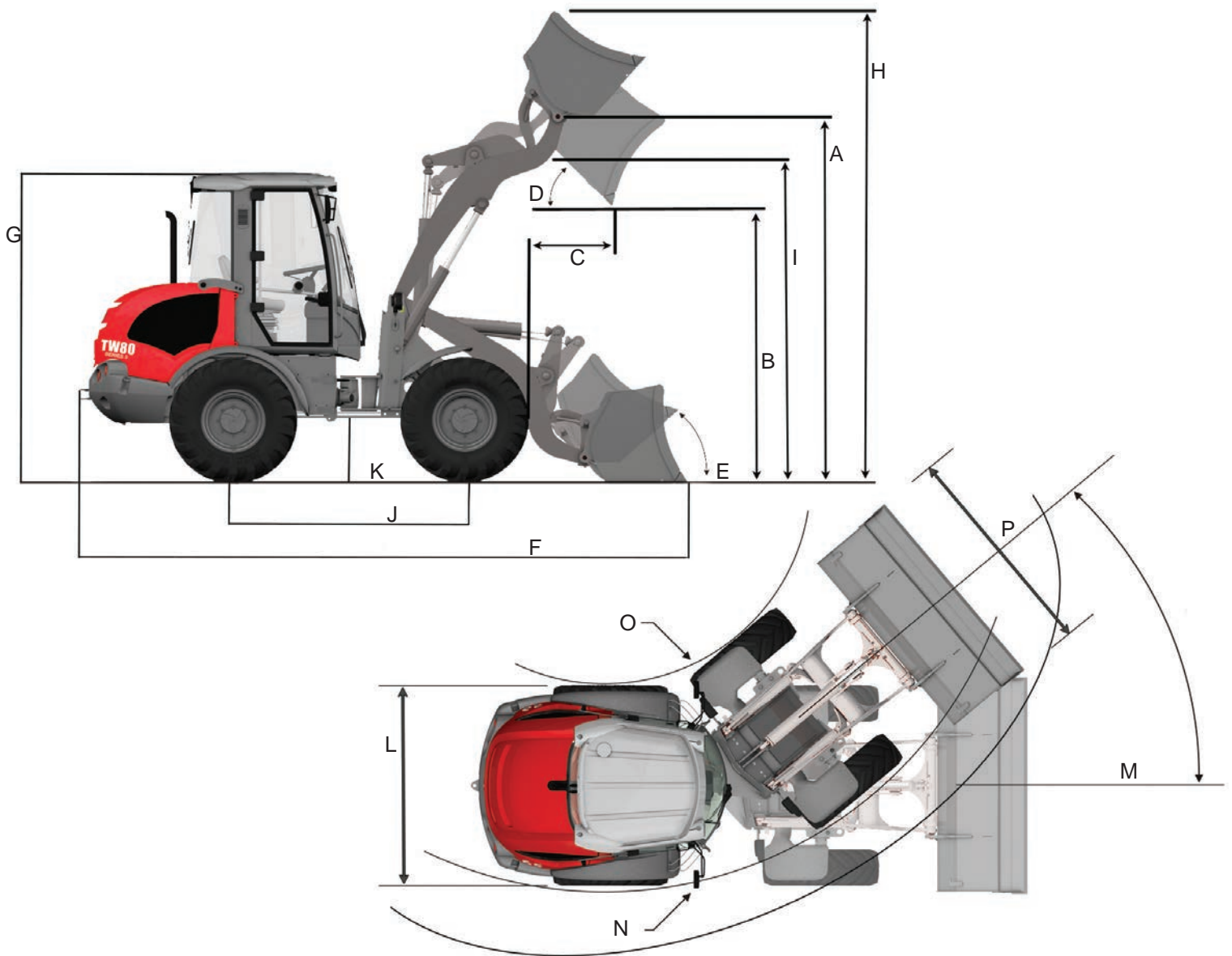

MACHINE DIMENSIONS

A	Max. Lift Height to Bucket Pin	11 ft 1.0 in	(3,380 mm)
B	Dump Height Fully Raised	8 ft 6.0 in	(2,605 mm)
C	Max. Reach Fully Raised	2 ft 5.0 in	(740 mm)
D	Dump Angle	45°	
E	Rollback Angle	48°	
F	Overall Length with Bucket	18 ft 3.0 in	(5,580 mm)
G	Overall Height	8 ft 11.5 in	(2,730 mm)
H	Overall Operating Height	13 ft 10.0 in	(4,220 mm)
I	Bucket Clearance Height	9 ft 11.0 in	(3,025 mm)
J	Wheel Base	7 ft 2.6 in	(2,200 mm)
K	Ground Clearance	1 ft 6.5 in	(470 mm)
L	Overall Width without Bucket	6 ft 9.0 in	(2,050 mm)
M	Turning Radius at Bucket Edge	14 ft 8.0 in	(4,478 mm)
N	Outside Turning Radius	13 ft 3.0 in	(4,046 mm)
O	Inside Turning Radius	6 ft 3.0 in	(1,898 mm)
P	Recommended Bucket Width	81.5 in	(2,070 mm)



2 YEAR
2,000 HOUR
FULL MACHINE
WARRANTY

© 2019 Takeuchi Manufacturing (U.S.), Ltd. All Rights Reserved. Printed in the U.S.A. In accordance with our established policy of continued improvement, specifications and features are subject to change without notice. Pictures may show options other than standard equipment.
FORM: TW80 Series 3 Wheel Loader Spec Sheet - Dec. 2019

TAKEUCHI
From World First to World Leader