

Compact Wheel Loader

takeuchi
From World First to World Leader

TW40



Product Features & Specifications

ENGINE

- U.S. EPA Interim Tier 4 Emission Compliant
- Three Cylinder Perkins Diesel Engine
- Turbocharged
- Engine Driven Fan
- Dual Element Air Cleaner with Restriction Indicator
- High Capacity Radiator and Hydraulic Oil Coolers Mounted Side-by-Side

ELECTRICAL

- 12 volt System with 95 amp Alternator
- Heavy Duty Battery, 800 CCA
- Work Lights: (2) Front and (2) Rear
- Road Lighting Package
- Back-up Alarm
- Horn

DRIVE TRAIN

- Hydrostatic Drive w/ 100% Inching Pedal
- Front Limited Slip Differential (45%)
- Two-Speed Travel
- Lever Operated Park Brake
- Hydrostatic and Hydraulic Drum Service Brakes
- Rigid Axles with Outboard Planetary Reduction
- Center Frame Oscillation 12° Left / 12° Right
- True Center Steering Articulation 40° Left / 40° Right
- Heavy Duty 31x15.5-16.5 Floation Tires

HYDRAULIC & WORKING EQUIPMENT

- Priority Steering
- Auxiliary Hydraulic Lines Plumbed to End of Loader Arms
- Continuous Flow Auxiliary Detent
- Hydraulic Oil Level Sight Gauge
- Loader Arm Float
- Hydraulic SSL Style Quick Attach Coupler
- Z-Bar Linkage
- 1/2" Flat Face Couplers (optional)

OPERATOR'S STATION

- Elevated Operator's Station
- Folding ROPS / FOPS Guard
- Deluxe Lighting Package includes Work, Driving and Signal Lights
- Multi-Functional Joystick for Machine Direction Fwd / Rev and Loader Controls: Lower, Curl, Dump
- Tilt Steering Column (canopy only)
- Enclosed Cab with Heat and Front and Rear Wipers (optional)



Operator's Station - Canopy



Operator's Station - Cab

TOUGH, POWERFUL, RELIABLE



Flotation Tires



Integrated Anchor Points



Monitor Display - Canopy



Monitor Display - Cab

The TW40 features a compact design that is ideal for maneuvering in tight spaces with minimal damage to lawns and other sensitive surfaces. Delivering 40 horsepower, the TW40 is equipped with a powerful, turbocharged Perkins engine that is Tier 4i compliant. The loader has excellent reach, dump height, and lifting capabilities making it suitable for a wide variety of applications, and the universal skid steer loader coupler greatly

improves attachment versatility. The operator's station is elevated and unobstructed for greater visibility and jobsite awareness. Excellent power and precise control result in increased productivity, and with lower operational and maintenance costs the TW40 is a great alternative to the skid steer loader.



Large Lockable Rear Service Hood Provides Outstanding Service and Maintenance Access

OPERATING PERFORMANCE

Operating Weight - Canopy	7,275 lbs	(3,300 kg)
Cab	7,720 lbs	(3,500 kg)
Tipping Load, Straight	3,858 lbs	(1,750 kg)
Tipping Load, Full Turn	3,417 lbs	(1,550 kg)
Operating Capacity, SAE J818*	1,708 lbs	(775 kg)
Bucket Breakout Force	4,878 lbs	(2,213 kg)
Lift Arm Breakout Force	4,181 lbs	(1,896 kg)
Traction Force	5,620 lbs	(2,549 kg)
Travel Speed - Low Range	4.0 mph	(6.5 km/hr)
High Range	12.4 mph	(20.0 km/hr)

* Rate Operating Capacity (ROC) for wheel loaders is rated with a bucket according to SAE J818 at no more than 50% of the full turn tipping load.

HYDRAULIC SYSTEM

Auxiliary Flow - Standard Flow	10.3 gpm	(39.0 Lpm)
System Operating Pressure	3,988 psi	(27.5 MPa)

ENGINE

Make/Model	Perkins / 403D-15T	
Emission Standard	U.S. EPA Interim Tier 4	
Engine Displacement	91 cu in	(1.49 L)
Horsepower @ 2,800 rpm	39.4 hp	(29.4 kW)
Maximum Torque @ 1,800 rpm	82 ft-lb	(112 Nm)

FLUID CAPACITIES

Engine Lubrications	5.8 qt	(5.5 L)
Cooling System	8.5 qt	(8.0 L)
Fuel Tank Capacity	18.5 gal	(70.0 L)
Fuel Consumption (65% of Full Load)	2.99 gal/hr	(11.37 L/hr)
Hydraulic Reservoir Capacity	7.4 gal	(28.0 L)
Front Axle Lubrication	4.2 qt	(4.0 L)
Rear Axle Lubrication	3.7 qt	(3.5 L)
Planetary Capacity (each)	0.7 qt	(0.6 L)



Center Frame Oscillation



Folding ROPS / FOPS



Road Lighting Package



Hydraulic Oil Sight Gauge

ATTACHMENTS

Takeuchi now offers attachments for all of your Takeuchi equipment. See your authorized Takeuchi dealer for addition information and attachment options.



4-in-1 Bucket



Low Profile Buckets



Grapple - Brush



Grapple - Scrap

TW40 Wheel Loader

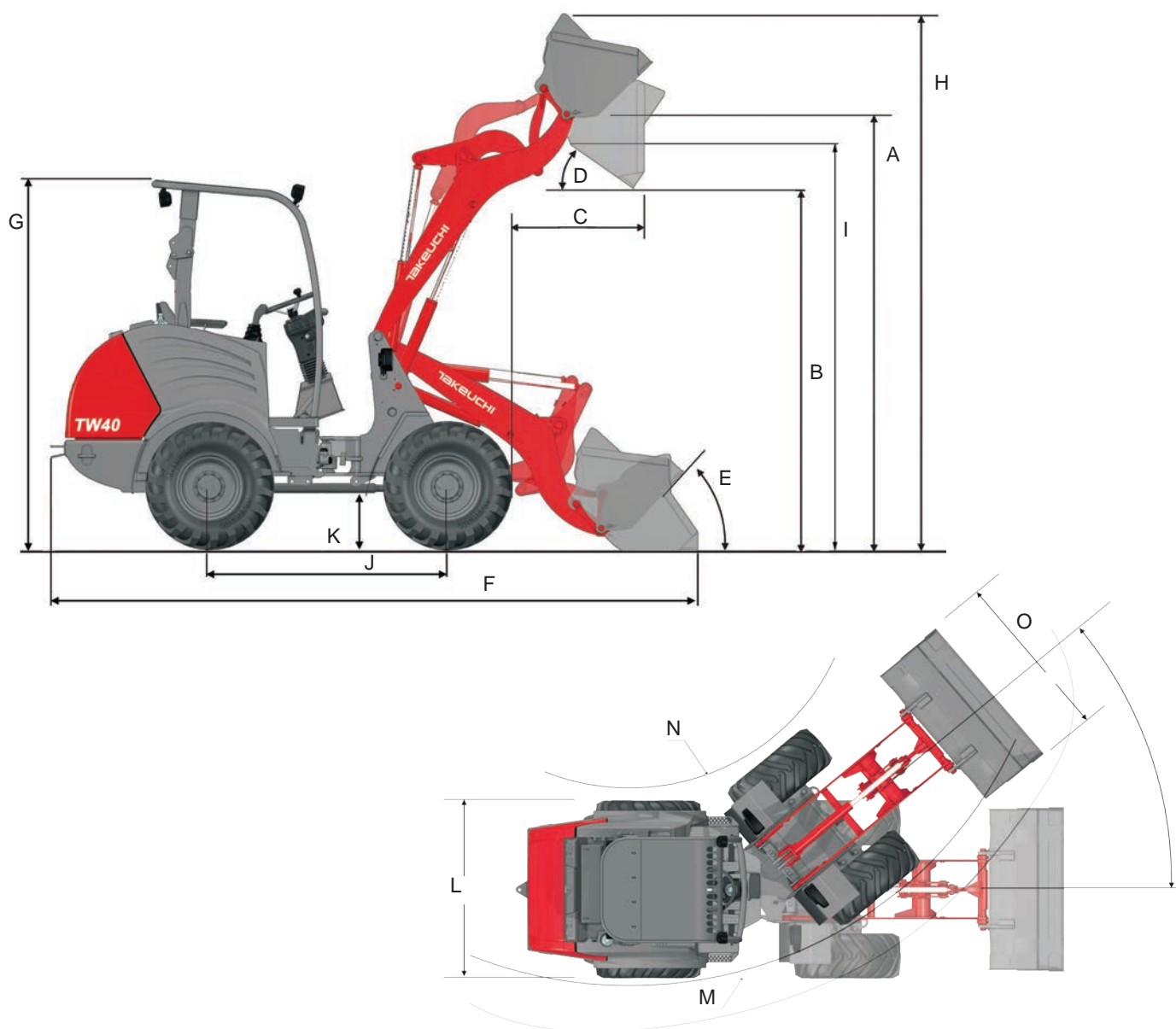

MACHINE DIMENSIONS

A	Max. Lift Height to Bucket Pin	9 ft 6.5 in	(2,907 mm)
B	Dump Height Fully Raised	7 ft 0.6 in	(2,150 mm)
C	Max. Reach Fully Raised	2 ft 8.2 in	(817 mm)
D	Dump Angle	34°	
E	Rollback Angle	51°	
F	Overall Length with Bucket	15 ft 5.0 in	(4,700 mm)
G	Overall Height	7 ft 10.5 in	(2,408 mm)
H	Overall Operating Height	11 ft 11.6 in	(3,648 mm)
I	Bucket Clearance Height	9 ft 0 in	(2,745 mm)
J	Wheel Base	5 ft 7.5 in	(1,715 mm)
K	Ground Clearance	1 ft 1.6 in	(345 mm)
L	Overall Width without Bucket	5 ft 0.0 in	(1,530 mm)
M	Outside Turning Radius	10 ft 4.5 in	(3,162 mm)
N	Inside Turning Radius	5 ft 2.8 in	(1,596 mm)
O	Recommended Bucket Width	60 in	(1,524 mm)



2 YEAR
2,000 HOUR
FULL MACHINE
WARRANTY

© 2017 Takeuchi Manufacturing (U.S.), Ltd. All Rights Reserved. Printed in the U.S.A. In accordance with our established policy of continued improvement, specifications and features are subject to change without notice. Pictures may show options other than standard equipment.
FORM: TW40 Wheel Loader Spec Sheet - Feb. 2017

TAKEUCHI
From World First to World Leader