

Takeuchi

Introduces the New

Job TB-1400

Compact Crawler

Backhoe



The TB-1400 is fully hydraulic and equipped with Isuzu Engine, 3ABI-07 which is very quiet, efficient and economical in fuel consumption.

TB-1400 can work as well as TB-1200 AL in restricted areas. Simple lever operation enables you to control the machine easily. As an added feature, it is equipped with a dozer blade which can also be used as an outrigger, to provide additional stability when working under difficult conditions.

You have the option of various sizes of buckets to meet the needs of the specific job.

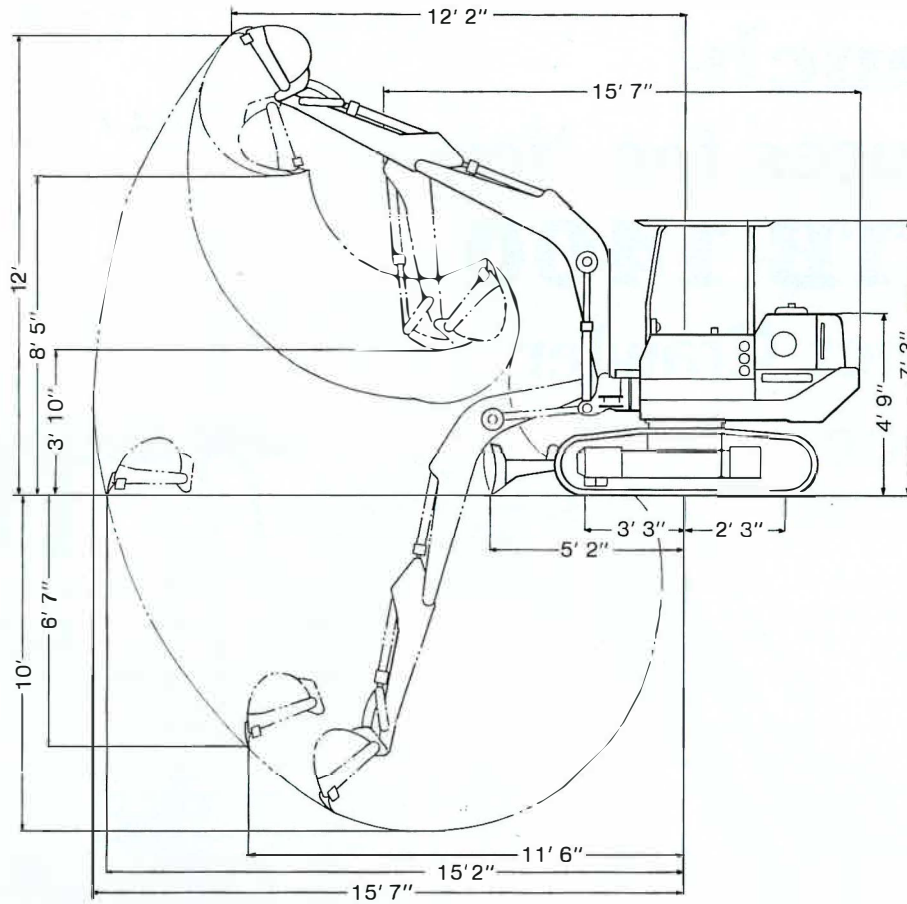

TAKEUCHI TB-1400 SPECIFICATIONS

DIMENSIONS

Overall weight (complete machine operating weight)	3310kg	7282 lbs.
Overall height (transport position)	2220mm	7'3"
Overall length (transport position)	4750mm	15'7"
Overall width	1675mm	5'6"
Clearance between axles and ground	330mm	13"
Dozer blade (width x height)	1600mm x 400mm	5'3" x 1'4"

BUCKET

Standard bucket	520mm-0.14m ³	20.5"-0.22 yds.
Optional bucket	390mm-0.10 ³	22.5"-0.19 yds.
	480mm-0.12 ³	18.9"-0.16 yds.
	570mm-0.16 ³	15.4"-0.14 yds.

WORKING PERFORMANCES

Maximum digging depth	3000mm	10'
Brake-out force (at bucket tooth)	2100kg/cm ²	4620 lbs.
(at stick boom)	1250kg/cm ²	2750 lbs.
Highest point at maximum extension	3665mm	12'
Maximum clearance height of dumping	2565mm	8'5"
Maximum digging radius from main body center	4640mm	15'2"
Dozer blade earth moving capacity	0.41m ³	0.56 yds.
Dozer blade maximum lifting clearance	350mm	13.8"
Dozer blade maximum lowering clearance	180mm	7.1"

OPERATION RANGES

Ground pressure	0.2892kg/cm ²	4.1124Lb/in ²
Travel speed	1.69km/h	1.06 m.p.h.
Gradeability	30°	
Traction force	2900kg	6394.5 lbs.
Boom swing (both to left and right)	50°	
Upper machine rotation	360°	
Upper machine rotation speed	11 r.p.m.	

In accordance with our established policy of constant improvement, we reserve the right to amend these specifications at any time without notice.

HYDRAULIC UNIT

Maximum hydraulic pressure	170kg/cm ²	2414psi
(dozer blade)	130kg/cm ²	1846psi
Number of hydraulic pumps	3	
Hydraulic pump	Gear pump	
Hydraulic pump discharge capacity	pump 1 & 2 ... 33.6L (8.9 gal.)	
	pump 3 ... 17.6L (4.7 gal.)	
Hydraulic tank capacity	125L	33 gal.
First pump drives	Rotation, right crawler, bucket	
Second pump drives	Boom, stick boom, left crawler, boom swing	
Third pump drives	Dozer blade	

ENGINE

Make and model	ISUZU, 3AB1	
Total displacement	1777cc	108.5 cubic inch
Rated output	28hp/2000r.p.m.	
Maximum torque	10.5kg-m/2000r.p.m.	1.449 ft-lb/2000r.p.m.
Compression ratio	20	
Cylinder bore x stroke	86mm x 102mm	3.3858" x 4.015881"
Number of cylinders	3	
Fuel consumption	210g/ps-h	0.79g.p.m.
Fuel tank capacity	38L	10.04 gal.

Distributor

Takeuchi Mfg. (U.S.), Ltd.

519 Bonnie Valentine Way
 Pendergrass, GA 30567
 Phone: 706-693-3600 / Fax: 706-693-3725