

HYDRAULIC EXCAVATOR

**takeuchi**  
From World First to World Leader

# TB210R



# Product Features & Specifications

## OPERATING PERFORMANCE

Operating Weight	2,370 lb	(1,075 kg)
Max. Bucket Breakout Force	2,518 lb	(1,142 kg)
Max. Arm Digging Force	1,439 lb	(653 kg)
Arm Length	2 ft 10.6 in	(880 mm)
Slew Speed	10.0 rpm	
Traction Force	2,878 lb	(1,305 kg)
Ground Pressure	4.1 psi	
Max. Travel Speed		
Low Range	1.2 mph	(2 km / hr)
High Range	2.3 mph	(3.7 km / hr)

## HYDRAULIC

Total Hydraulic Flow	5.9 gal / min	(22.2 L / min)
Auxiliary Hydraulic Flow	5.9 gal / min	(22.2 L / min)
System Operating Pressure	2,680 psi	(18.2 mpa)

## ENGINE

Model / Make	Kubota / D722-E4B	
Displacement	43.9 cu in	(.72 L)
Horsepower @ 2,200	11.7 hp	(8.7 kW)
Max. Torque @ 1,900 rpm	26.4 ft-lb	(35.8 Nm)

## FLUID CAPACITIES

Engine Lubrication	3.0 qt	(2.8 L)
Cooling System	4.2 qt	(4.0 L)
Fuel Tank Capacity	3.3 gal	(12.4 L)
Hydraulic Reservoir Capacity	2.3 gal	(9.0 L)
Hydraulic System Capacity	4.0 gal	(15.0 L)



Dual side entry



Retractable undercarriage and blade



Minimal Tail Swing



Foldable ROPS

## ENGINE

- Three Cylinder Kubota Engine
- U.S. EPA Final Tier 4 Emission Compliant
- Engine Driven Fan
- Dual Element Air Coolant
- Automatic Fuel Bleed System

## ELECTRICAL

- Multi-Informational Display
- 12 volt System with 40 amp Alternator
- Boom Mounted Work Light
- Engine Preheat
- Hour Meter
- Travel Alarm

## UNDERCARRIAGE AND FRAME

- Hydraulically Retractable Track Frame
- Low and High Range Travel
- Backfill Blade with Pin-on Extensions
- Protective Counterweight

## HYDRAULIC

- Pilot Operated Joystick Controls
- Tandem Gear Pumps
- Auxiliary Hydraulic Circuit Plumbed to Arm
- Selectable One-way and Two-way Auxiliary Operation
- Pilot Accumulator
- Hydraulic Tank with Fluid Level Sight Gauge
- Foot Controlled Auxiliary Hydraulics with Detent for Hand Tools

## WORKING EQUIPMENT

- Top Mount Boom Cylinder
- Minimal Tail Swing
- Long Arm
- Hydraulics Lines Protected in Boom and Arm
- Boom Swing 85° Left & Right
- Cushioned Boom Cylinder
- Dual Pin Position Bucket (optional)

## OPERATOR'S STATION

- ROPS / TOPS Two Post Foldable Frame
- Pattern Change Valve
- Foot Controlled Auxiliary Hydraulics
- 2" Retractable Seat Belt

# TB210R Compact Excavator

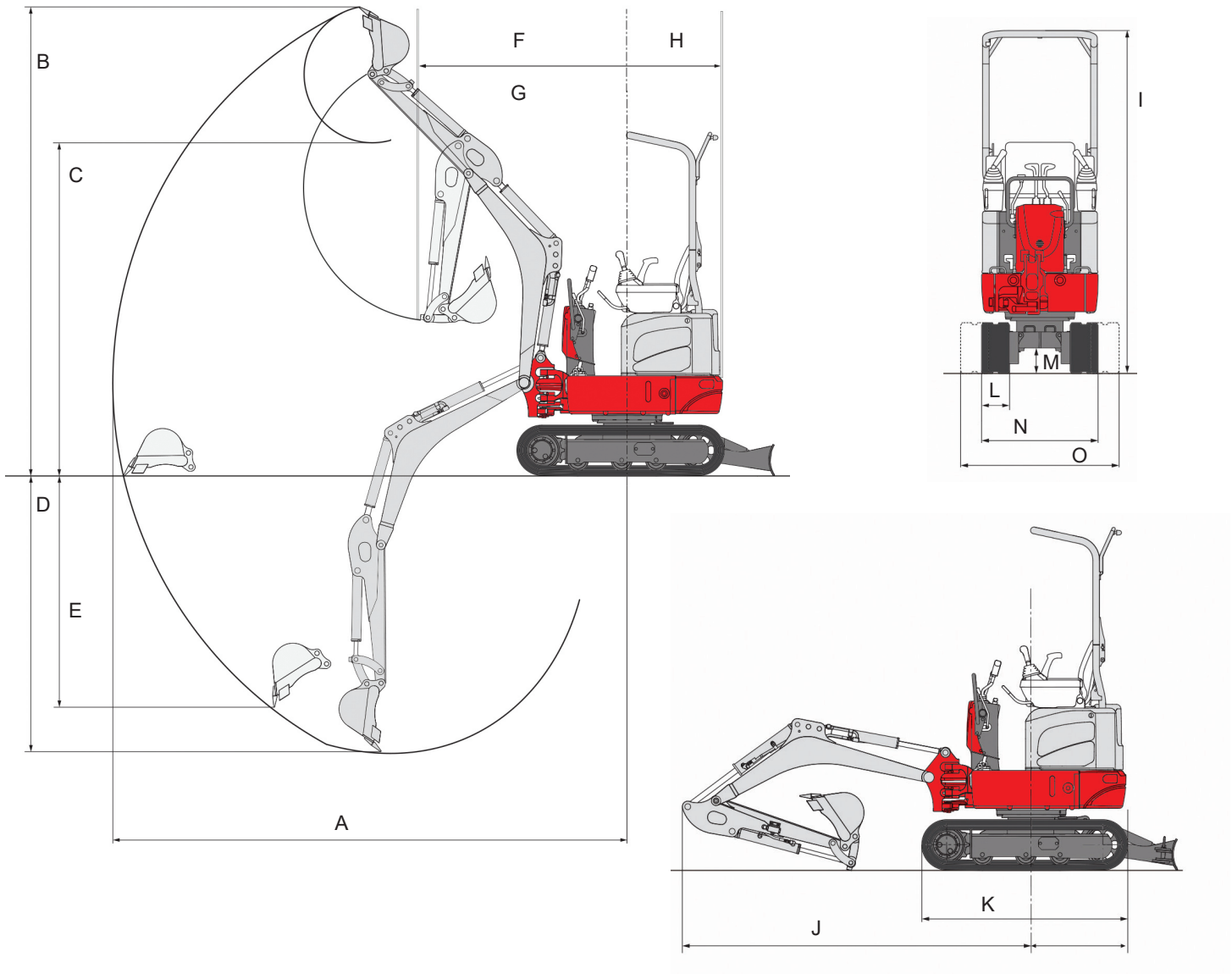

## MACHINE DIMENSIONS

A	Maximum Reach	10 ft 9.4 in	(3,285 mm)
B	Maximum Dig Height	9 ft 9.5 in	(2,985 mm)
C	Maximum Dump Height	6 ft 11.5 in	(2,120 mm)
D	Maximum Dig Depth	5 ft 9.1 in	(1,755 mm)
E	Maximum Vertical Dig Depth	4 ft 10 in	(1,475 mm)
F	Front Swing Radius	4 ft 4 in	(1,320 mm)
G	Front Swing Radius (Offset)	3 ft 2.5 in	(980 mm)
H	Tail Swing Radius	2 ft 0 in	(610 mm)
I	Transport Height	7 ft 2.6 in	(2,200 mm)
J	Transport Length	9 ft 8.3 in	(2,955 mm)
K	Undercarriage Length	4 ft 4.2 in	(1,325 mm)
L	Track Width	7.1 in	(180 mm)
M	Ground Clearance	6.2 in	(157 mm)
N	Track Width Retracted	29.5 in	(750 mm)
O	Track Width Extended	40.2 in	(1,020 mm)



**Excellent Serviceability**

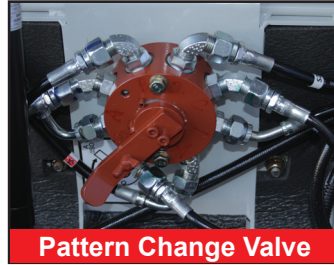

**Pattern Change Valve**



**Foldable Foot Pedals**



**Two-Speed Travel**

The TB210R features many upgrades that will enhance operator comfort, efficiency, and serviceability. To improve fine control and reduce fatigue, the TB210R now features pilot operated joystick controls that are low effort and responsive to operator input.

Additionally, an ISO/SAE pattern change valve has been added enabling the operator to choose their preferred operational pattern. The boom cylinder is now mounted on top of the boom for greater

protection and improved routing of the hydraulic lines which are run through the boom and arm. A hydraulically retractable track frame and the addition of a foldable ROPS frame allow it to easily pass through a standard doorway.

To reduce the likelihood of rear swing impacts, the TB210R also features a short tail swing design. Despite its compact dimensions, service access is exceptional thanks to the tilt-up seat pedestal and access panels.



**Spacious Operator's Station with New Pilot Operated Joysticks**