

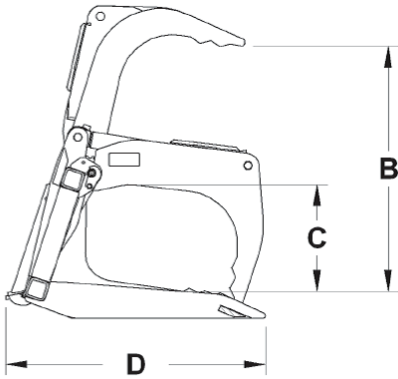

Brush Grapple - Medium and Heavy-Duty

- Solid bottom to handle scrap and small debris
- Heavy-duty hinges and pins to distribute load
- 1/2" Connect under pressure couplers for simplified hose connections
- Standard cylinder guards protect cylinder components
- Standard load check valve
- 1 1/4" cylinder pivot pins
- 1 1/4" x 24" patented grapple pins reduce torsional force
- High strength reinforced bottom
- Large diameter cushioned cylinders
- Reversible 3/4" x 8" bolt-on cutting edge standard
- 1 Year Limited Warranty



SPECIFICATIONS	60" MD	66" MD	72" MD	
Overall Width	60.75"	66.75"	72.75"	
B. Height - Open	33"	33"	33"	
C. Height - Closed	17.4"	17.4"	17.4"	
D. Overall Depth	36"	36"	36"	
Number of Tines	11	12	14	
SPECIFICATIONS	72" HD	78" HD	84" HD	90" HD
Overall Width	72"	78"	84"	90"
B. Height - Open	40"	40"	40"	40"
C. Height - Closed	16.5"	16.5"	16.5"	16.5"
D. Overall Depth	38"	38"	38"	38"
Number of Tines	14	14	16	16

COMPATIBILITY	PART NUMBER	WEIGHT	SSL				CTL			CWL						
			TS50R	TS60R	TS50V	TS60V	TS70R	TS70V	TS80R-2	TS80V-2	TL8	TL10	TL12	TW40	TW65-2	TW80-2
60" Scrap Grapple - Medium Duty (Full Bottom)	AGS60MD	725 lbs.	*1	*1	*1	*1										
66" Scrap Grapple - Medium Duty (Full Bottom)	AGS66MD	788 lbs.	●	●	●	●	*1	*1	*1	*1	●			●		
72" Scrap Grapple - Medium Duty (Full Bottom)	AGS72MD	835 lbs.					●	●	●	●						
76" Scrap Grapple - Heavy Duty (Full Bottom)	AGS76HD	1,081 lbs.					●	●	●	●					*2	*2
82" Scrap Grapple - Heavy Duty (Full Bottom)	AGS82HD	1,133 lbs.					●	●	●	●	●	●			*2	*2
88" Scrap Grapple - Heavy Duty (Full Bottom)	AGS88HD	1,180 lbs.					●	●	●	●	●	●			*2	*2

*1 = Compatible with wheels reversed to narrow position

*2 = Compatible when used with SSL coupler adaptor